



YING SHUN
MACHINERY INDUSTRY CO., LTD.

Horizontal Milling Machine

YSM-26H SERIES



MECHANICAL FEATURE

- The main casting part is made of meehanite casting.
- The spindle is one piece machined from SCM440 alloysteel, high-frequency and precision polishing.
- X/Y axis are using precision ball screw.
- Inverter type used YASKAWA VFD.

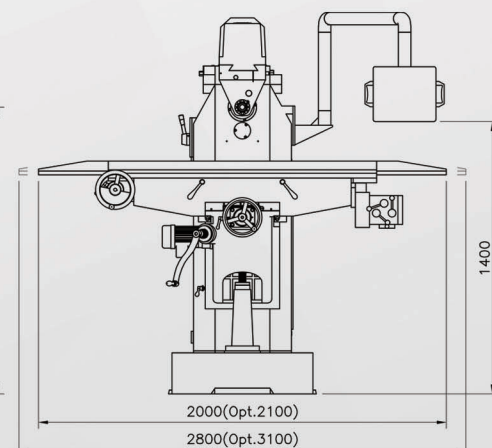
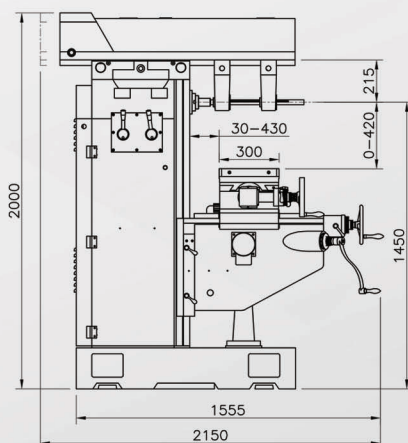
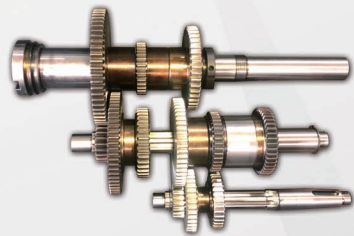

MECHANICAL DIMENSIONS

SPECIFICATONS AND ACCESSORIES

Model	Unit	26HS	26HC
Travel			
Longitudinal travel (M./A.)	mm	800 (Opt.1000)	
Cross travel (M./A.)	mm	400	
Vertical travel (M./A.)	mm	420	
Slideway X/Y/Z	type	△ / □ / □	
Overarm travel	mm	700	
Dist. from spindle center to table	mm	0-420	
Table			
Dimension	mm	1270x300 (Opt.1370x300)	
T-slots (WidthxNo.xPitch)	mm	16x3x70	
Spindle			
Milling	type	9 Steps	Inverter
Speed	60Hz	rpm	92-1614
	50Hz	rpm	73-1288
Horizontal Taper	type	NT40	
Motor			
Horizontal spindle	HP	5 (Opt.7.5)	
X axis traverse	HP	1/2	
Z axis elevation	HP	1/2	
feedrate			
X/Y axis speed	mm/min	30-1300 (9 Setps)	
Z axis speed	mm/min	345	
Machine			
Net Weight	kg	2000	

Standard accessries

- Draw bar
- Tool box and tools
- Front finned bellows cover on Y axis
- Back chip cover on Y axis
- Auto lubrication system
- Working lamp
- X axis gear box
- Z Axis Rapid up/down
- Deluxe type operation panel
- Electric box
- Ball scerw (X/Y)
- Horizontal bracket (2 pcs/set)
- Horizontal arbor (25.4mm)

Optional accessories

- Power drawbar
- Power feed(Y)
- Servo feed(X/Y)
- Gear box(Y)
- Digital readout (DRO)
- Coolant system(Pump 1/8HP)
- Chip tray



YING SHUN MACHINERY INDUSTRY CO., LTD.

All specification , dimension and design characteristics shown in this catalogue are subject to change without notice.

No.5,Aly.162,Ln.136,Sec.1,Jiahou Rd.,Houli Dist., Taichung City 421,Taiwan(R.O.C.)

TEL:+886-4-25586346

ys@yingshun.com.tw

FAX:+886-4-25586930

<https://www.yingshun.com.tw>