

E series

1, 2 and 3 axes

30i E model



20i E model



10i E model



Common characteristics, E series

EDM mode: to set the activation level of the EDM program. Any level may be changed even during the EDM process.

6 digital outputs

To control up to 6 penetration levels.

4 digital inputs

For axis zero setting and emergency input.

Electrode length compensation

The outputs may be disabled during the EDM operation for measuring or replacing the electrode.

30i E model

The 30i E model includes the following features:

- Bolt-hole drilling
- Linear drilling
- Hold

Comparison table

	M series milling machines and boring mills				T series lathes				E series EDM and grinders			General series general purpose applications		
	40i P	40i	30i M	20i M	40i TS	40i	30i T	20i T	30i E	20i E	10i E	40i	20i	10i
feedback														
connection to 1 Vpp and SSI encoders	4	3			4	3						3		
connection to TTL encoders	4	3	3	3	4	3	3	2	3	2	1	3	2	1
linear axes	•	•	•	•	•	•	•	•	•	•	•	•	•	•
angular encoders	•	•	•	•					•	•	•	•	•	•
incremental and distance-coded reference marks	•	•	•	•	•	•	•	•	•	•	•	•	•	•
linear axis sag compensation	•	•	•	•	•	•	•	•	•	•	•	•	•	•
multi-point compensation (points per axis)	100	100	40	40	100	100	40	40	40	40	40	100	40	40
1 Vpp signal monitoring	•	•			•	•						•		
travel limit alarm	•	•	•	•	•	•	•	•	•	•	•	•	•	•
display														
5.7" color TFT screen	•	•			•	•						•		
LED display			•	•			•	•	•	•	•		•	•
number of axes	4	3	3	2	4	3	3	2	3	2	1	3	2	1
radius or diameter display	•	•	•	•	•	•	•	•				•	•	•
mm/inch conversion	•	•	•	•	•	•	•	•	•	•	•	•	•	•
fine / coarse resolution	•	•	•	•	•	•	•	•	•	•	•	•	•	•
absolute / incremental feedback	•	•	•	•	•	•	•	•	•	•	•	•	•	•
"display off" mode	•	•	•	•	•	•	•	•	•	•	•	•	•	•
axis coupling	•	•	•	•	•	•	•	•	•	•	•	•	•	
functions														
zero setting of the axes	•	•	•	•	•	•	•	•	•	•	•	•	•	•
buzzer function	•	•	•	•	•	•	•	•	•			•		
number of references - part zeros	100	100	20	20					20	20	20	100		
number of tools	16	16			100	100	20	20				16/100		
axis preset	•	•	•	•	•	•	•	•	•	•	•	•	•	•
tool compensation	•	•	•	•					•	•	•	•		
axis feedrate display	•	•			•	•	•					•		
calculator	•	•	•	•	•	•	•	•	•			•		
easy setup	•	•	•	•	•	•	•	•	•	•	•	•	•	•
electrode length compensation									•	•	•			
hysteresis factor			•	•			•	•	•	•	•		•	•
cycles														
part centering cycles	•	•	•	•					•	•	•	•	•	•
bolt hole drilling (with the most recent data saved in memory)	•	•	•	•					•			•		
linear drilling	•	•	•	•					•			•		
grid pattern drilling	•	•										•		
EDM mode									•	•	•			
corner rounding / machining of arcs			•	•					•					
go to a particular position	•	•				•						•		
angle measuring	•	•	•	•					•			•		
taper calculation					•	•	•	•				•		
turning					•	•						•		
facing					•	•						•		
assisted threading (easy threading)						•						•		
on-screen guided help, with graphics	•	•			•	•						•		
storage of many part-programs	•													
others														
USB connection for copying data	•	•			•	•						•		
auto shut-off after 30-minute idle	•	•	•	•	•	•	•	•	•	•	•	•	•	•
digital inputs / outputs					15/11				4/6	4/6	4/6			
analog inputs / outputs					1/1									
probe	•	•				•						•		

Accessories

Support arm



- For mill ARM 300 model, 300 mm long
ARM 500 model, 500 mm long



- For lathe ARM-V-500 model
500 mm long

Adapter plate



- For built-in model

Operating conditions

Power supply protected against AC mains outage

universal power supply with an input range between 85 VAC and 264 VAC. Frequency from 45 Hz to 400 Hz

Operating temperature

from 5 °C to 45 °C (from 41°F to 113 °F)

Storage temperature

from -25 °C to 70 °C (from -13 °F to 158 °F)

relative humidity

maximum 95% without condensation at 45 °C (113 °F)

Sealing

front panel IP54 and rear panel IP4X (DIN 40050)

Product in compliance with safety and electromagnetic compatibility regulations

EN-60204-1, EN-50081-2, EN 55011, EN-55022, EN-55082, EN- 610004-2, 3,4, 5,6,11. EN-V50140, EN-V50141, ENV 50204 and EC directives 73/23/ECC, 89/392/CEE, 89/336/ECC and 73/23/ECC

Type of feedback signals

TTL and differential TTL (EIA422).

Plus, 1 Vpp and SSI on the 40i models

Maximum feedback frequency

250 KHz

Dimensions in mm

10i, 20i, 30i models

Tabletop models

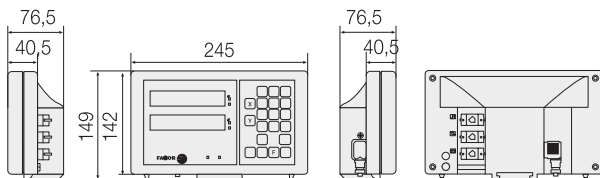

Built-in models

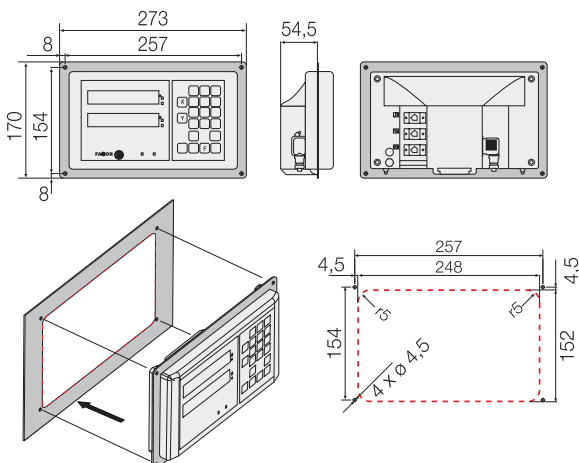

(*) Built-in option: Add "B" to the model (for example: 20i-B)

40i models

Tabletop models

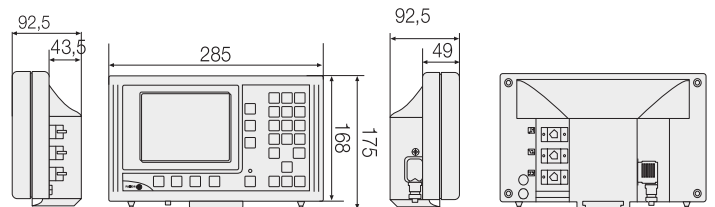

Built-in models

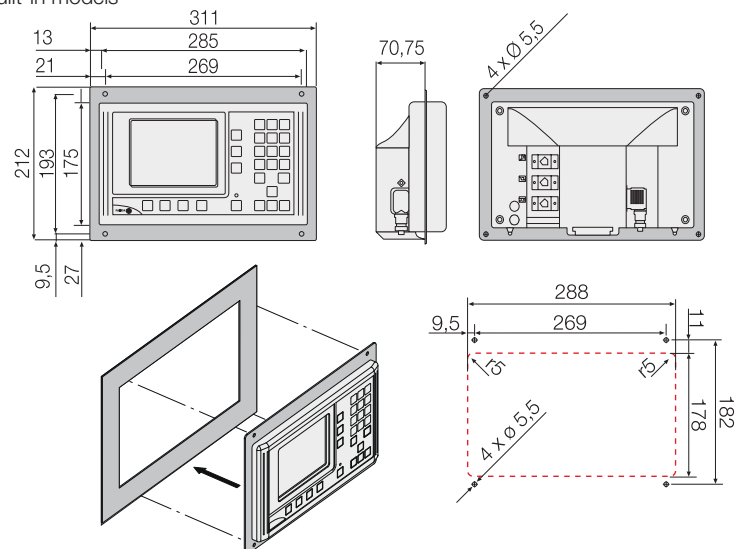

(*) Built-in option: Add "B" to the model (for example: 40i-B)