

“At Nampa Valley Helicopters, industrial accident prevention is always foremost. When we evaluated ergonomic lifting equipment, preventing back injuries was a key. Sky Hook is doing the job so well here at Nampa Valley Helicopters, we need another unit!”

-John Nielson, Nampa Valley Helicopters, Inc.



Attitude is Everything!

# MODEL 8560



Accessory 8510 Series Nylon Sling shown above  
(Sold separately)

- Designed to lift heavy or awkward objects without the need for a counterweight
- Load limit 500 lbs. (227 kg)
- Sky Hook weighs 26 lbs. (11.8 kg)
- Base weighs 78 lbs. (35.4 kg)
- Prevents lifting injuries
- Does the work of 4 people
- Meets O.S.H.A. requirements

#### Lifting Applications

Ideal for any lifting and moving application. This compact, stable design is perfect for tight, hard-to-reach locations.

industry leader since 1969

# SKY HOOK

# MODEL 8560 w/CHERRY PICKER BASE

**Sky Hook Model 8560 w/Cherry Picker Base is perfect** for lifting heavy or awkward objects from their shipping or packaging materials because its one-handed operation does the work of four people. Smaller and more agile than the traditional cherry picker, Model 8560's compact design makes it perfect for tight, hard-to-reach areas.

**Ideal for straddling a crate—and also designed so the legs** can go under something without requiring a counterweight—Model 8560 is an efficient and easy way to have enough leverage to retrieve the item you need to move. Unlike other cherry picker designs, Model 8560 has the flexibility of 15° rotation in each direction from center, allowing a full 30° range of motion when working in tight areas.

**Designed to pass through narrow doors** and tight hard-to-reach areas, Model 8560 functions well in all buildings (not just large plants) and is less expensive than a forklift, overhead crane, or chain hoist. For specialty applications, custom units of Sky Hook Model 8560 are also available.

For more descriptive product info visit [www.skyhookmfr.com](http://www.skyhookmfr.com)

## Features & Benefits

- Designed to lift heavy or awkward objects without the need for a counterweight
- Prevents lifting injuries
- Uses one hand operation that does the work of 4 people
- Safely lift & position up to 500 lbs. (227 kg) with one person
- Designed for precision positioning
- Operates in tight working conditions
- Is totally maintenance free
- Has removable boom
- Disassembles for easy transport and storage
- Designed to fit a 3 ft. (91.4 cm) standard aisle and tight hard-to-reach areas
- Has a limited manufacturer's warranty
- Meets applicable O.S.H.A. requirements

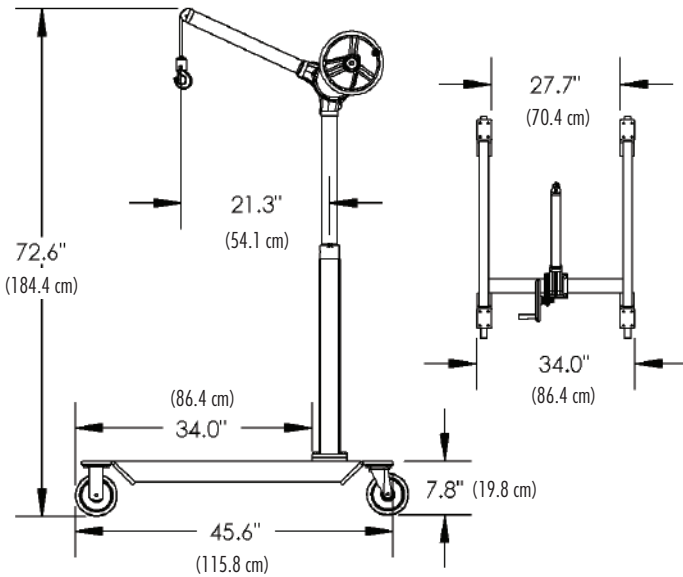

## Specifications

- Load limit 500 lbs. (227 kg)
- Sky Hook weighs 26 lbs. (11.8 kg)
- Base weighs 78 lbs. (35.4 kg)
- Pivots 15° in each direction from center
- 75" (190.5 cm) Length of lift
- Overall height of Sky Hook from floor is 72.6" (184.4 cm)
- One rotation of hand wheel = approx. 1" (2.5 cm) of vertical lift
- 6" (15.2 cm) Casters allow for easy movement
- Fits through a standard 3'0" (91.4 cm) door
- Constructed of high-strength steel

## Accessories



**Choker Collar**  
Accessory Model 8507



**Chuck Hook**  
Accessory Model 8520

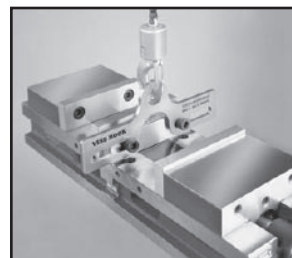

**Vise Hook**  
Accessory Model 8515



**Nylon Sling**  
Accessory Model 8510  
Series



Attitude is Everything!

[www.skyhookmfr.com](http://www.skyhookmfr.com)

ATTCO, INC. DBA  
**SYCLONE ATTCO SERVICE**  
P.O. Box 458, Emmett, ID 83617

**800-4SKYHOOK (800-475-9466)**

Fax: 800-973-3355

E-mail: [info@skyhookmfr.com](mailto:info@skyhookmfr.com)